

DUCT HUMIDITY TRANSMITTER (GDH-420)

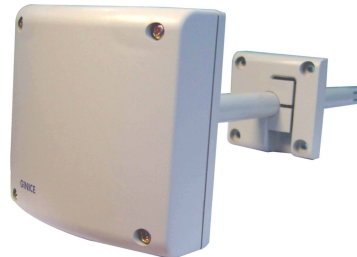

Application

"GDH" Duct Humidity Transmitter is intended for an electronic Humidity Transmitter to measure the Duct Relative Humidity(RH) and convert the measurement into an electric signal.

Equipment Combinations

This unit can be used with all system equipments that can receive output signals 4-20mADC of the detector.

Operating Mode

- Electronic sensing circuit varies signal into 4~20mADC(within 0~100% relative humidity)
- Sensing Accuracy is $\pm 3\%$ within usable range of 20~90%RH

Technical Data

- SUPPLY VOLTAGE : 24V AC/DC $\pm 20\%$
- FREQUENCY : 50 or 60Hz
- SENSING ELEMENT : Integrated Circuit
- POWER CONSUMPTION : Below 0.5VA
- SENSING RANGE : 0 ~ 100%RH
- ACCURACY at 20°C : at 20~90%RH within $\pm 3\%$ RH
- OUTPUT SIGNAL : 4~20mA DC
- SENSING TIME : Approx, 20sec(velocity 20m/s)
- AMBIENT TEMPERATURE :
 - 1) On Operation: -15 ~ +58°C
 - 2) On Transportation & Storage : -25 ~ +65°C

- AMBIENT HUMIDITY :
 - 1) On Operation: 5~ 100%RH
 - 2) On Transportation: below 95%RH
- PROTECTION CLASS : IP54
- CABLE FITTING : PF 1/2"
- WEIGHT : 0.17Kg(W/BRACKET)

Mounting Notes

- Installation Location :

When the detector has to be mounted on supply duct, the detector must be kept Between 3 to 8 meters from the humidifier unit.
- For accurate measurement of the relative humidity, Follow recommendation as ;
 - Steam humidifier; between 5 to 8 meters
 - Spray water fogger; between 3 to 10 meters

Wiring Diagram

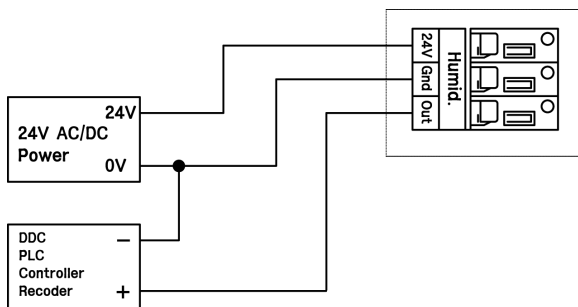

Dimension

