

OUTSIDE HUMIDITY TRANSMITTER (GOH-420)



Application

"GOH" Outside Humidity Transmitters are intended for an electronic Humidity Transmitter to measure the outside Relative Humidity (RH) and convert the measurement into an electric signal.

Equipment Combinations

This unit can be used with all system equipments that can receive output signals 4-20mADC of the detector.

Operating Mode

- Electronic sensing circuit varies signal into 4~20mADC (within 0~100% relative humidity)
- Sensing Accuracy is $\pm 3\%$ within usable range of 20~90%RH

Technical Data

- SUPPLY VOLTAGE : 24V AC/DC $\pm 20\%$
- FREQUENCY : 50 or 60Hz
- SENSING ELEMENT : Integrated Circuit
- POWER CONSUMPTION : 0.35VA
- SENSING RANGE : 0~100%RH
- Accuracy at 20°C : At 20~80%RH Within $\pm 3\%$ RH
- OUTPUT SIGNAL : 4-20mA DC
- SENSING TIME : Approx, 20sec
- AMBIENT TEMPERATURE :
 - 1) On Operation: -35 ~ +80°C
 - 2) On Transportation & Storage: -25 ~ +65°C
- AMBIENT HUMIDITY :
 - 1) On Operation: below 100%Rh
 - 2) On Transportation & Storage: below 95%RH

- WIRING : wires, 1.0mm² or Shield Cable
- WEIGHT : 0.06Kg
- HOUSING : plastic case
- PROTECTION CLASS : IP 30

Mounting Notes

- The element must not be touched and should be protected from dust, water, spray and condensation.
- The sensor element must not be exposed to organic solvents, sulphid bearing materials.
- Select a location approx 1.5 meter above the floor.
- The sensor location should also be reasonably clean and free from damp and condensation.
- Fix with the bolts provided in pull box(50 × 100, 100× 100)
- To avoid the conductive current the wires should be separated from power lines.
- Use the shield line when wiring.

Wiring Diagram

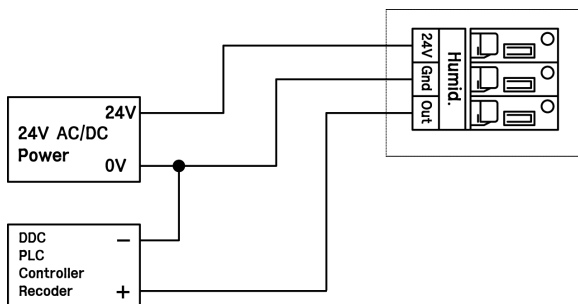

Dimension

